

Driver Fatigue Detection System

E. Rogado, J.L. García, R. Barea, L.M. Bergasa, *Member IEEE* and E. López

Abstract—Abstract – This paper presents a method for detecting the early signs of fatigue/drowsiness during driving. Analysing some biological and environmental variables, it is possible to detect the loss of alertness prior to the driver falling asleep. As a result of this analysis, the system will determine if the subject is able to drive. Heart rate variability (HRV), steering-wheel grip pressure, as well as temperature difference between the inside and outside of the vehicle, make possible to estimate in an indirect way the driver's fatigue level. A hardware system has been developed to acquire and process these variables, as well as an algorithm to detect beats and calculate the HRV taking into account the others aspects mentioned before.

Index Terms - ECG, HRV, Inattention, Fatigue, Drowsiness.

I. INTRODUCTION

Based on researches done by the Real Automóvil Club de España (RACE), driver drowsiness involves a high percentage (30%) of traffic accidents.

This is a complex phenomenon that implies a decrease in alerts and conscious levels of the driver. It is no possible measure it up with direct methods, but it can derive from visual features (movements, expressions) or no visual (physiological variables like HRV, brain activity, etcetera).

Being able to detect driver's state in each moment and using this information in a driver-vehicle system, may lead to the development of a more intelligent driver assistance system which will prevent car accidents.

The objective of this study will be design a non-invasive system which could monitor the indoor environmental conditions as well as the driver, in order to determine the alert and attention levels. The biological data, which was acquired by different sensors, will be stored, processed and evaluated on real time by a system capable to detect the early signs of fatigue, since the physiological variables are intimately related to this phenomenon.

This paper describes the system used for detecting the fatigue during driving in section II. The general architecture (hardware and software) of the system implemented in section III and IV. In section V some results with professional driver are showed. Section V shows conclusion and future works for detecting the driver fatigue state during driving.

The authors want to express their gratitude to the Education and Science Ministry and to the Madrid Community and to the University of Alcalá because of financing the projects "Cabinas inteligentes para el transporte en carretera" (PSE-370100-2007-2) and SLAM-MULEX (CCG07-UAH/DPI-1736).

II. FATIGUE DETECTION DURING DRIVING

The fatigue/inattention/drowsiness are very vague concepts. These terms refers a loss of alertness of vigilance while driving. Indicators of fatigue can be found in [1].

A. Visual Features

There is an important quantity of studies related with this area [2]. Most of them are based on facial recognition systems to determine the position of the driver's head, the frequency of blinking, etc.

This frequency and the degree of eyelid opening are good indicators of tiredness level [3]. In a normal situation, driver blinks and moves the eyes quickly and constantly, keeping a large space between eyelids. In a sleepy state, we can appreciate that the speed of blinking and the opening decrease.

With regard to the driver's head angle in a normal situation, he maintains a lifted up position and only does the typical movements related to the driving. Passing into a drowsy state implies to nod off as well as a more frequent head's position change. In fact, when it is a deep stage, the nodding off is extremely slow and the head keeps itself completely relaxing [4].

Other research lines are centered in the analysis about facial expression. In general, people are prone to have different expression depending on the alert level that show [5].

B. Non-visual Features

Driver's concentration can be affected by environmental factors, therefore it would be interesting to sensorize the cabin. Diverse studies analyze the concentration of carbon monoxide and oxygen in air. An intelligent gas sensing system offers an added security in the vehicle, warning when the concentration is higher than tolerable levels (CO of 30 ppm and oxygen levels below 19.5%) [6].

Other non-visual features are physiological variables. Galvanic skin response (GSR) and the conductivity are relation to the psychological state of the person [7]. Gripping force gives us an idea about driver's attention level, and body temperature is an important physiological parameter that depends on driver's state too: body temperature increases due to infections, fever, etc. reflecting the autonomic responses and the activity of a human's autonomic nervous system [8]. Electroencephalogram gives a lot psychophysiological information about stress state, drowsiness or emotional reactions [9].

Nevertheless, electrocardiogram and heart rate variability are ones of the most important variables. In fact,

power spectrum can be calculated as a Fourier discrete transform of the HRV, and, knowing the relation between the person's state and his/her spectrum, determine the driver's psychophysiological conditions. The parameters of interest are the total power (from 0.03 to 0.4 hertz), low frequency power (from 0.05 to 0.15 hertz) and high frequency power (from 0.15 to 0.4 hertz) [10].

The acquisition of the HRV has been made amplifying and filtering an ECG signal, with the purpose of detecting to QRS complex and calculating the time between consecutive R waves. When the separation between R waves is obtained, this could be represented in function of the beat graphically. In our case, it is interesting to calculate the histogram and the frequency response. The heart rate variability gives us some information about the respiratory system (increase in respiration and decrease in exhaling), vasomotor system, temperature changes (causes little changes in HRV) and central nervous system, that is in direct relation with the person's emotional state.

Finally, not only physic but also mental state can influence in the way of driving. The biggest automakers focus their efforts in this direction. Citroen has elaborated a system that detects the step of a line (continuous or discontinuous) when the indicator has not been activated [11]. Moreover, abrupt direction changes, variations in the way of the brake or in the driver's body position (evaluated through pressure sensors in the seat) are others relevant parameters to take into account for the analysis of the driver's alert state.

III. HARDWARE IMPLEMENTATION

It is necessary an adequate hardware to obtain the biological variables that the algorithm needs for its processing.

The developed system is made up of an analogical subsystem and other digital. The first one of them does an adaptation of the signal to acquire it through an analogical to digital converter. The second one filters and processes the resulting signal that it was gotten in the analogical phase. Furthermore, the digital system is able to send information in a wireless way using bluetooth or zigbee.

A. Analog Subsystem

This subsystem the pressure that driver exerts over the steering-wheel of the vehicle, the electrocardiographical signal coming from some ECG electrodes, as well as the pulse through a commercial cardiothoracic belt (figure 1).

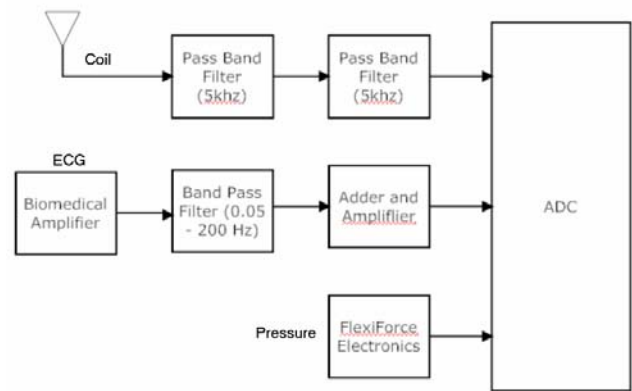

Fig. 1 Analog subsystem.

Some piezoresistive force sensors FlexiForce [12] are used to measure a voltage which is proportional to the applied force. Using an appropriate electronic that the manufacturer prescribes us, we can get a signal which is limited between zero and five volt that will be acquired by the ADC of the microcontroller. Electronics were adjusted to achieve an adequate sensitivity level for our necessities. Thus, when the driver is holding the steering-wheel, the resulting voltage is higher than the established threshold previously.

Electrocardiographical signal is gotten by ECG electrodes, a circuit based on a precision instrumentation amplifier INA114 and a band-pass filter to remove both high frequency and continuous component. Next, adaptation electronics were added to set the signal inside the dynamic range of the ADC.

Although the pulse could be calculated by the ECG signal, other possibility has been added to receive this pulse signal using a commercial cardiothoracic belt utilized by sportsmen. To make this possible, a receiver has been implemented to work at the same frequency that the belt emits (5 kHz). Its circuit is made up of an amplifier and a band-pass filter. When cardiothoracic belt detects a pulse, it emits a sinusoidal wave at 5 kHz. The microcontroller detects this sinusoid, and therefore the pulse, and is able to calculate the HRV directly.

B. Digital Subsystem

Digital system acquires the signals of the analogical to digital converter and processes them according to the developed algorithm. This system is based on an Atmel ATmega128 microcontroller that has eight channels of high-accuracy 10 bit A/D Converter and high-speed program execution (16 MHz) that is enough for the application. Figure 2 shows this subsystem.

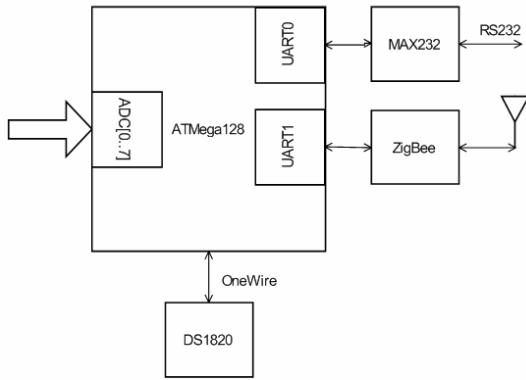

Fig. 2 Digital system. It is the one that receives the analogical signals, to digitize and process them. It also obtains temperature information and it has wireless communication capabilities.

Microcontroller can communicate using the serial port (RS232) or using a Bluetooth or Zigbee wireless module in order to send the results of the processing to a central system or debug the system during the execution.

Indoor and outdoor temperature is measured by a DS1820 one-wire digital temperature sensor from Maxim.

Figure 3 shows the system implemented.



Fig. 3. Implemented system running. In the steering wheel there are two ECG electrodes and the presure sensors connected to the hardware.

C. Acquisition Card

To perform the test in the laboratory, a National Instruments LabWindows Real-Time target (PCI-6014) connected with the analogical subsystem and a Logitech commercial steering-wheel has been used. Both electrocardiographical and pressure sensors has been situated over the steering-wheel which may detect the angle of the same thanks to the electronic integrated on it. If the steering-wheel is connected by USB, different movements and keystrokes of the button can be detected using the appropriate driver of LabWindows. Its precision is about one tenth of degree. The measurement of the position of the steering-wheel provides other variable that can be used to detect changes in the driver's behavior as a consequence of a sleepy state. Referring to a real car, it could use an encoder or an angle sensor with enough precision.

Nowadays, mostly cars offers this data (steering-wheel angle) by means on-board computer using a CAN bus.

IV. SOFTWARE IMPLEMENTATION

Our system uses two types of software: one for the microcontroller ATmega128, and another one for the computer with a wireless link among both devices using bluetooth or zigbee.

In a global way, in figure 4 the flow diagram of the complete application is shown. The software has been implemented to carry out the following realtime functions:

- 1) Signals acquisition coming from the sensors.
- 2) Signals filtering.
- 3) Signals processing.
- 4) Analysis of the results in a combined way to detect the first symptoms of fatigue.

The pulse measuring stage is very important for the HRV calculation that is the main parameter in which our study is based. Hence, and as we already mention previously, we use two different methods to detect the beats with in order to implement a more robust algorithm that, before any unexpected event, allow to detect those correctly. The algorithm is based on a dynamic threshold since the QRS complexes cannot present the same amplitude in different people [13]. Previously, it has been necessary to filter the obtained signal with a pass band digital filter and to derive the filtered signal. The result is squared obtaining a significant peak for each QRS complex. Also, to develop the algorithms and the study in a comfortable way has been used LabWindows with an acquisition card PCI-6014 of National Instruments.

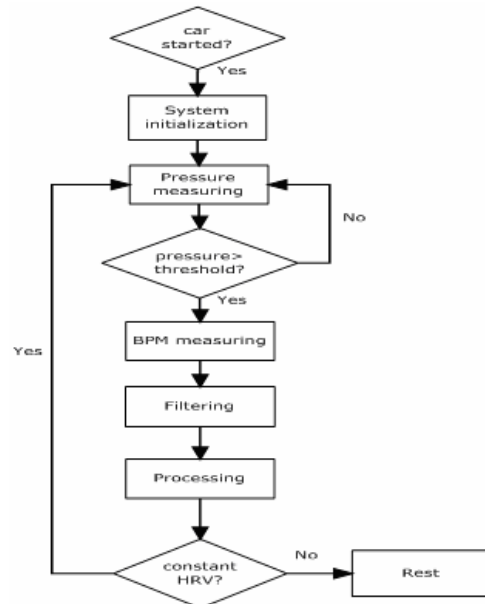

Fig. 4 Software's flow diagram

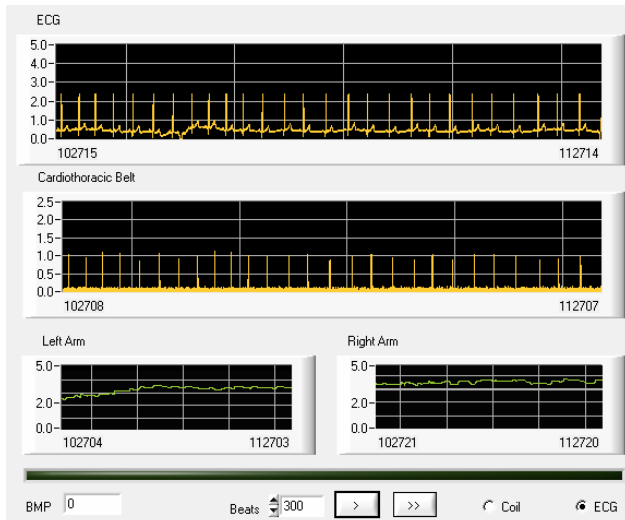

Fig. 5. Pulse detection detail using the software's graphical interface implemented in LabWindows. Top image shows the signal captured through the ECG electrodes. Under it, signal of a commercial cardiothoracic belt is shown. Finally, the signals obtained from the pressure sensors are observed.

The captured signals and the results obtained are stored in the PC's hard disk for their later study. To evaluate the driver's state in each moment, our algorithm combines the information about the physiologic parameters to offer the most appropriate decision considering the existent relationship among the different indicators.

Using the HRV signal we study the frequency response. It is carried out an interpolation over those calculated HRV values. With the interpolated signal statistical and spectral indexes are calculated. The statistical ones are calculated directly using the interpolated signal and they are the mean, the variance and the root mean square. The spectral ones are obtained using the power spectrum calculated using a FFT. The interest parameters are the total power (from 0.03-0.4 Hz), the very low frequencies power (VLF, from 0.03-0.05), the low frequencies power (LF, from 0.05-0.15), the high frequency power (HF, from 0.15-0.4) and the relationship between LF and HF (Fig. 6).

The steering wheel position is obtained using a LabWindows's driver for a Logitech's commercial steering wheel. In our case it's necessary to detect the angle, carrying out it with a precision to tenths of a degree. The position is sampled every 0.05 seconds and it's stored in a file. Also, each 200 samples the mean and the typical deviation of the steering wheel angle are calculated. The objective is to detect an important variation in the typical deviation (figure 7).

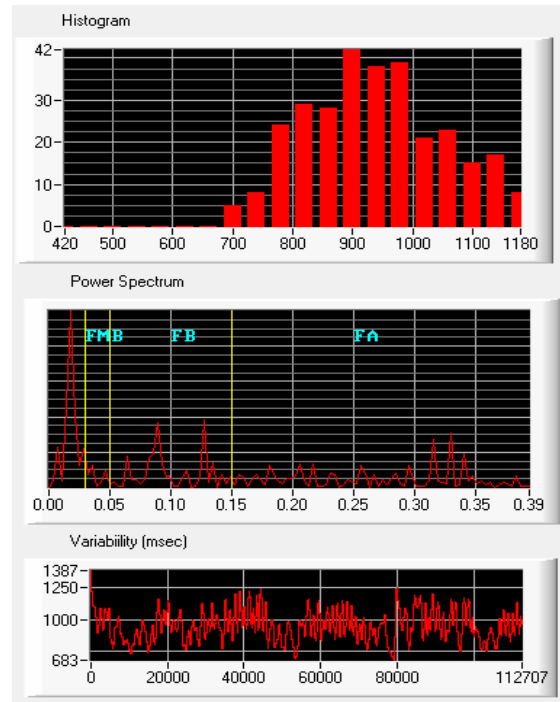

Fig. 6. HRV analysis using LabWindows. Top image is the fellow's HRV histogram obtained during the driving. Below power spectrum and heart rate variability are shown.

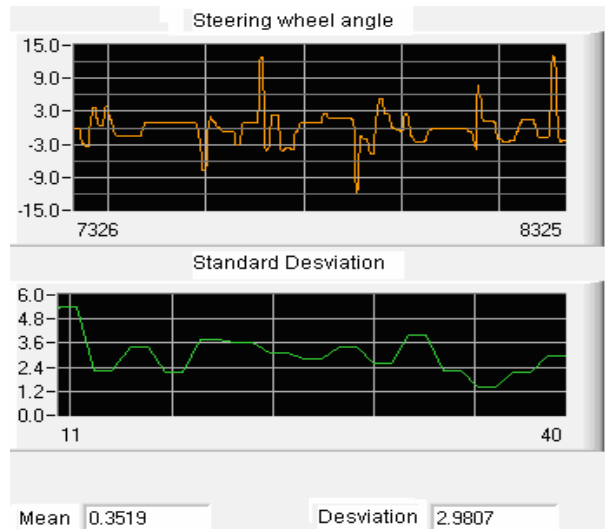

Fig. 7. Detection of the steering wheel movements.

Also, to simulate a conduction environment in the laboratory a small game has been created, controlled with the steering wheel, in which objects that appears in the screen should be dodged. In this way we can detect the driver's normal variability during a normal conduction state and compare it with the one that we obtain of the same driver when it suffers drowsiness (Fig. 8).

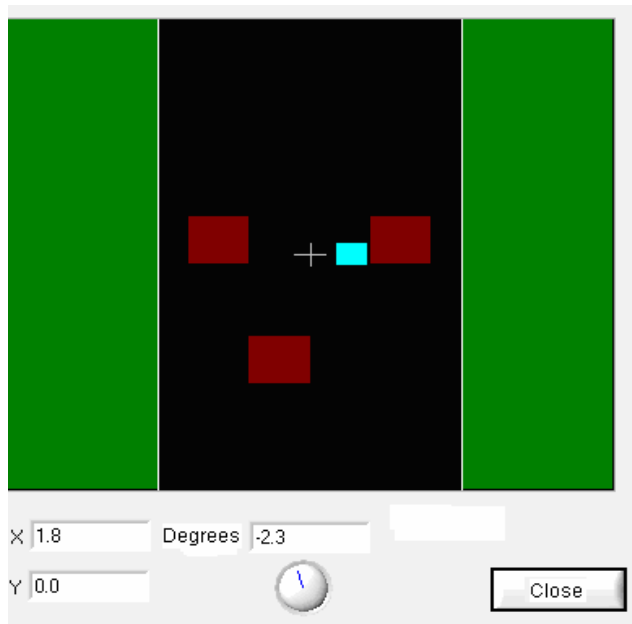

Fig. 8. Driving simulation.

V. RESULTS

With the simulation system installed in a laboratory we are carrying out tests on people with a healthy heart in a comfortable environment to get to sleep. The final system that we are using at the laboratory uses LabWindows to take samples of the pressure exercised on the steering wheel by each hand, of the electrocardiogram signal (both of them: the one obtained using the sensors located in the steering wheel and the one obtained by the commercial cardiothoracic belt) and of the steering wheel position every 0.05 seconds.

The system, besides storing the samples for their later study, also has the capacity to analyze them presenting in graphic the signals that are being obtained as well as the power spectrum and the HRV signal histogram, and the mean and typical deviation of the steering wheel position.

In figure 9 can be observed the HRV captured for the same person under conditions of extreme fatigue (24 hours without sleeping) and in different days. The test consists on placing the user on the simulator and to try that this falls asleep driving. In HRV 1 and 2 the driver falls asleep although he wakes up immediately. In HRV 3 the driver doesn't fall asleep although due the fatigue he yawns continually.

Using the captured files and after the analysis of that ones we could affirm that, in the case of a tired person, certain HRV variations belong together with the first drowsiness symptoms. As we relax ourselves, HRV increases (pulsations diminish). When the first nod off happen a considerable drop of the HRV takes place. In figure 10 can be observed that the HRV slope is growing, what it means that the driver is relaxed and that's involve a possible situation of danger in the highway.

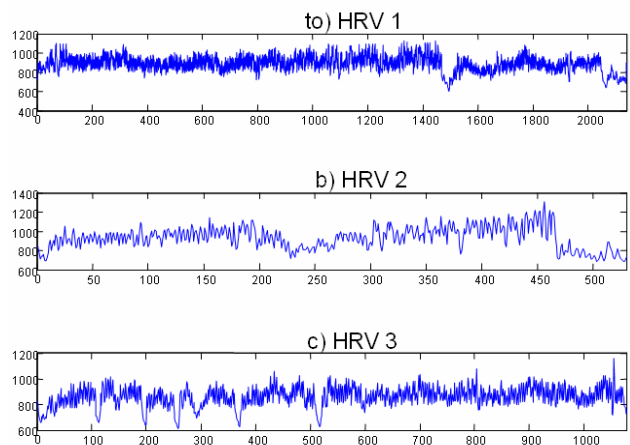

Fig. 9 HRV examples under extreme fatigue conditions.

In the carried out tests, when the person is in an alert state, HRV oscillates showing the sinusal frequency (more or less), but when one gives the first nod off (first symptom of the drowsiness) HRV falls abruptly maintaining its value constant during about 10 beats approximately. Calculating the HRV frequency, it's observed that, after this nod off, the value of the frequency it's higher to their previous medium value. This fact can be appreciated in figure 10. When these two conditions take place simultaneously, then we could affirm that there are appearing the first symptoms of fatigue.

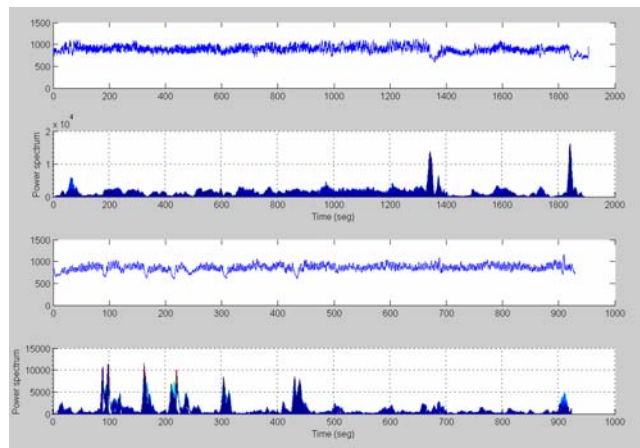

Fig. 10. HRV examples under extreme fatigue conditions with sleep attack and yawns (doze).

If the driver is awake and attentive, abrupt changes in HRV mentioned previously are nonexistent. In fact, in the figure 11 can be observed perfectly that, although takes place a HRV slight fall that stays constant during some samples, the frequency has a little variation respect to their medium value.

Although it is certain that with the exposed examples it seems that with HRV one can deduce when the driver will fall asleep, this it is not this way due to their variability. The previous results had been obtained in situations of rest and

total silence, but in later studies with people that have driven maintaining a conversation, laughing, etc, we have obtained very similar results to those gotten in the drowsiness case, the main difference is that in these cases an HRV increase is not detected and therefore the person is not in the relaxation phase next to the sleepy state (Fig. 12).

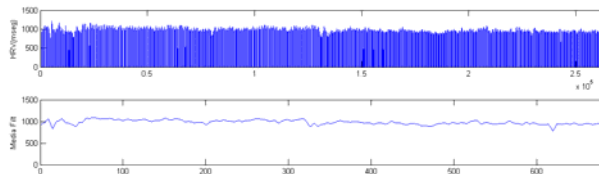

Fig. 11 Relaxed person's HRV.

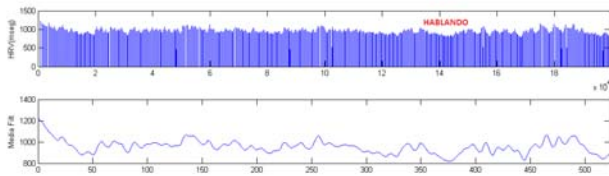

Fig. 12 An awake driver's HRV analysis. The driver is speaking.

At the moment we are working in developing new algorithms that allow us to determine the user's state and to consider HRV like a valid signal to determine the driver's state. We are comparing our results with other obtained by means of PERCLOS (Percent Eye Closure) and others based on actions carried out by the driver (steering wheel angle). For it, is made use of the simulator developed inside the CABINTEC project that models a truck head (Fig. 13).



Fig. 13. Trunk simulator.

VI. CONCLUSION

Most of the systems designed to detect the driver's state are based on the study of visual facts (eyes movement, head movement, facial expression) or non visual facts (HRV, ECG, pressure exercised over the steering wheel, relative humidity, etc). Detecting the fatigue with a single physiological parameter is not possible, becoming necessary the study of diverse variables. In this work we have been

studied the HRV variability during the conduction and to account for this information, combining it with others to be able to evaluate the driver's state.

In systems which are based on the study of the heart rate variability, in the power spectrum and in the histogram, it is necessary a minimum number of samples to obtain valid results. Hence, it is required to obtain a minimum number of beats before considering these data as valid. That requires a minimum time before the obtained results are reliable.

Our objective is to combine this information with visual information and with the driving environment (road conditions, climate, etc) to detect the drowsiness during the conduction and in this way to reduce the risks and dangers for the drivers.

These systems are not only useful for the driver's security also they are the base to develop register devices that make easy the reconstruction and investigation of accidents storing driving related data, state of the driver and driving environment.

REFERENCES

- [1] R. Bittner, K. Hána, L. Poušek, P. Smrka, P. Schreib and P. Vysoký, Detecting of Fatigue States of a Car Driver, ISMDA 2000, LNCS 1933, pp. 260–274, 2000.
- [2] G. Scharenbroch, Safety vehicles using adaptive interface technology (SAVE-IT) (Task 10): Technology review. Delphi electronics and safety systems Tech. Rep., 2005
- [3] Qiang Ji, Zhiwei Zhu, y Peilin Lan: Real-Time Nonintrusive Monitoring and Prediction of Driver Fatigue. *IEEE Transactions on Vehicular Technology*, vol. 53, n°. 4, July 2004.
- [4] Mai Suzuki, Nozomi Yamamoto, Osami Yamamoto, Tomoaki Nakano, y Shin Yamamoto: Measurement of Driver's Consciousness by Image Processing-A Method for Presuming Driver's Drowsiness by Eye-Blinks coping with Individual Differences - 2006 *IEEE International Conference on Systems, Man, and Cybernetics*
- [5] Haisong Gu, Qiang Ji†, Zhiwei Zhu: Active Facial Tracking for Fatigue Detection. *Applications of Computer Vision, 2002. (WACV 2002)*
- [6] Galatsis, K.; Wlodarski, W.; Li, Y.X.; Kalantar-zadeh, K.: Vehicle cabin air quality monitor using gas sensors for improved safety. *Optoelectronic and Microelectronic Materials and Devices, 2000. COMMAD 2000. Proceedings Conference on Volume, Issue, 2000 Page(s): 65 - 68*
- [7] F. Nasoz, O. Ozyer, C. L. Lisetti, and N. Finkelstein, "Multimodal affective driver interfaces for future cars," in *Proc. ACM Int. Multimedia Conf. Exhibition, 2002*, pp. 319–322.
- [8] Axisa, F. Dittmar, A. Delhomme, G.: Smart clothes for the monitoring in real time and conditions of physiological, emotional and sensorial reactions of human. *Microcapteurs et Microsyst. Biomedicaux*, INSA Lyon, Villeurbanne, France;
- [9] Lin, Y.Leng, H. Yang, G. Cai, H.: An Intelligent Noninvasive Sensor for Driver Pulse Wave Measurement. *Sensors Journal, IEEE*
- [10] Claudia Lerma González, Oscar Infante Vázquez y Marco V. José: Sistema de Análisis de la Variabilidad de la Frecuencia Cardíaca.
- [11] <http://www.citroen.es/CWE/esES/AboutCitroen/TECHNOLOGIES/SECURITY/AFIL/AFIL.htm>
- [12] <http://www.tekscan.com/flexiforce/flexiforce.html>
- [13] Serhiy Matviyenko: Low-cost EKG Pulsometer. *CYPRESS Application note*